

Study Platform for AC Transmission System of High-Speed Train

Xiaochun Fang^{1, a}, Zhongping Yang^{1, b}, Fei Lin^{1, c}, Jinfei Qin^{1, d}

¹School of Electrical Engineering, Beijing Jiaotong University, China

^ame330221789@126.com, ^bzhpyang@bjtu.edu.cn, ^cflin@bjtu.edu.cn, ^d11125720@bjtu.edu.cn

Keywords: study platform, transmission system, high-speed train, co-simulation

Abstract. Demand for CRH (China Railways High-Speed) trains, both in quantity and types, is increasing because of the rapid development of high-speed railway in China. To support the improvement and development the AC transmission system of these trains, a study platform is proposed in this paper. Target of the platform is supporting the study which contains design, verification, display etc. in detail. Platform framework is described in this paper. And the results of study on transmission system temperature rise and energy-saving operation strategy of high-speed train based on the platform are displayed. Availability of the study platform is verified.

Induction

The China High-speed Railway is developing rapidly. According to the statistics from UIC (International Union of Railways), high-speed lines with length of 13539km will be opened up in China by the end of 2012 [1]. With continuing development of high-speed railway in China, 18000km high-speed lines will be opened up by 2020 according to *Mid/Long-Term Development Planning of China Railway* [2]. The rapid development of high-speed railway in China leads to increasing demand for CRH trains, both in quantity and types. Different performances of high-speed trains are required due to the variety of line conditions and operation environment. Therefore, improving and redesigning the transmission system of existing CRH trains are inevitable.

It's hard and complicated to study the high-speed transmission system. The study costs a lot of time, materials and money including the simulation, real train experiment and practical operation. Some unreasonable design of transformers' and motors' allowance and performance hasn't usually been discovered until testing the real train. In this way, it wastes a lot of time and increase the costs. Furthermore, it's really hard for the real train experiment to change operation conditions.

Therefore, a study platform for AC transmission system of high-speed train is developed. It contains the software platform and experiment platform which are connected by CAN communication. Software platform is used to model a train and simulate the train in diversiform line conditions and operation environment. Results of the operation simulation are provided to control the experiment platform. Control algorithms, temperature-rise effect of the transmission system, energy-saving operation of the train etc. can be study by the platform.

Platform framework

In this paper, the study platform for transmission system of high-speed train will go through the entire design and develop process. The platform integrates design, validation and display platform as a whole.

Based on function analysis and design, the study platform includes the host computer, hardware

experiment platform, analog driver console and three-dimensional visual projection equipment. The optimization supporting software and 3D visual simulation software is built-in host computer. Focusing on the platform target, a specific structure, which is shown in Fig.1, of the study platform has been set up. Data interaction between software platform and experiment platform is also shown in Fig.1.

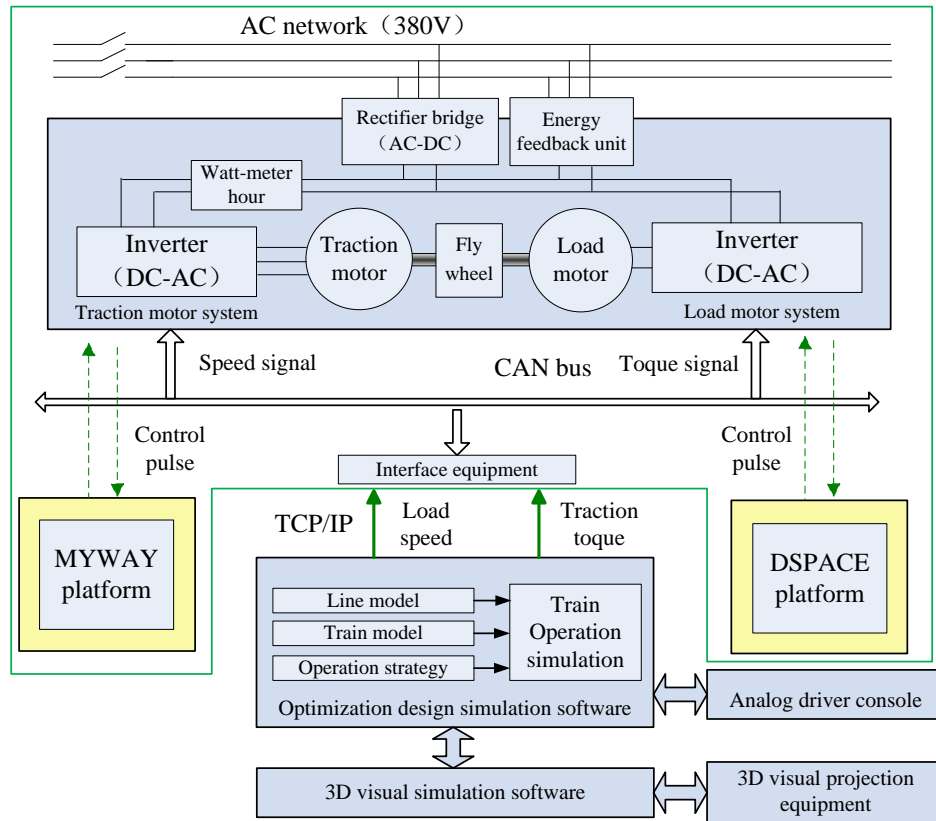

Fig. 1 Specific structure of the study platform has been set up.

Software platform. Completing the model building and system design, providing virtual operation environment for the hardware experiment platform, and providing a background control for the 3D visual simulation, the software for optimization and design is a key module of the study platform. Simulation software consists of five main parts. They are basic data setting, internal subsystems of the train modeling, comprehensive simulation, interfaces and results analysis. References describe the software platform in detail [3].

Experiment platform. The experiment platform mainly consists of the traction motor load torque simulation platform. The traction motor load torque simulation system is built in order to study the operation characteristics of high-speed train traction motor and control method of AC transmission system in laboratory condition. It is the key part of the study platform.

This experiment platform includes two connected induction motors. One is used as traction motor; the other is used as load motor. According to the simulation of changing load in different operation situations, the change of some important physical quantities of the drive system can be calculated correspondingly. The simulation platform is composed by two parts. One is the traction motor system controlled by MYWAY and the other is the load motor system controlled by DSPACE. Vector control method is adopted to control the two inverters. The toque command and speed command are provided for the traction motor and the load motor respectively. References provide the control method of the load toque simulation platform in detail [4]. A block diagram of the system control algorithm is given in Fig. 2.

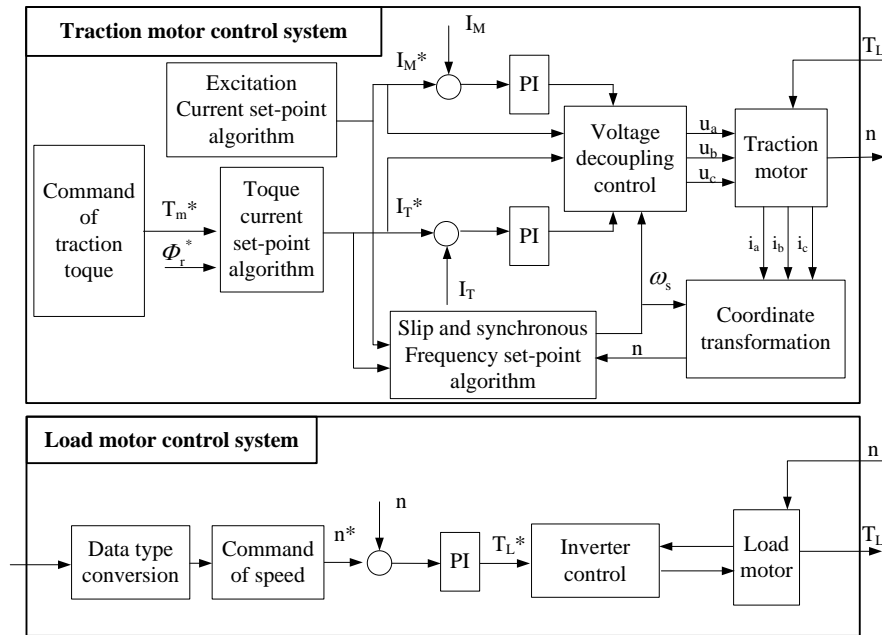

Fig. 2 The block diagram of the experiment platform control algorithm.

Application of the study platform

Study on transmission system temperature rise. On transmission study platform, the temperature rise of converters and inverters is measured by some temperature measuring devices as thermal imager. The thermal simulation of converters and inverters is done by FLOTHERM [5] and compared with the experiment results. Fig.3 shows the results compare of converter. The highest temperature is 44.6°C of simulation on the left. The experimental temperature is 45.2°C on the right. They are close. Fig.4 shows the comparison results of inverter. The left one shows the result of the thermal simulation in which the highest temperature on the surface of radiator is 89.2°C. The right one shows the result in experiment in which the highest temperature is 84.6°C. From the contrast diagram, both the temperature distribution on the surface of radiator and the highest temperature of radiator are close to a degree. The research on the thermal and electric properties of traction drive system is done with this platform.

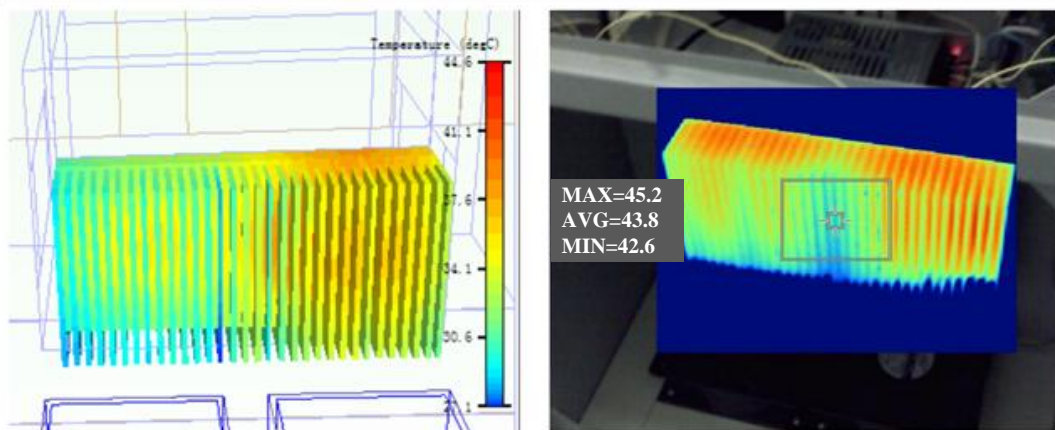

Fig.3 Compare of converter temperature rise in experiment and simulation

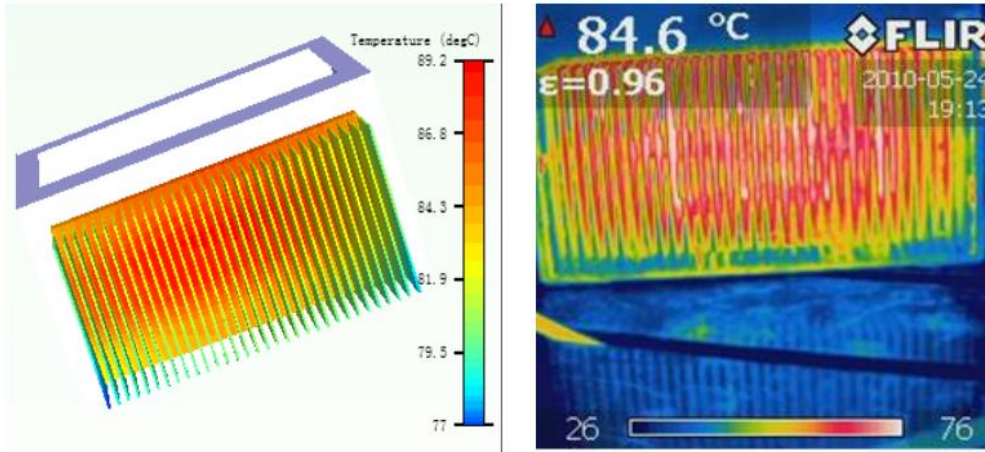

Fig.4 Compare of inverter temperature rise in experiment and simulation

The study on energy-saving operation strategy of high-speed train. Train operation on the line from Xuzhou to Bengbu which is a part of Beijing-Shanghai line is simulated on this platform. The line is 155.698km long. The fixed running time is 3014 s. The torque scaling coefficient is 0.002631 and the rotational speed scaling coefficient is 2.6683.

At first, distributing time equally operation strategy is applied. Fig. 5 shows the result. The result shows that the motor rotational speed follows the speed instruction value well. The output torque is positive in traction conditions, zero in coasting conditions and negative in braking conditions. It is verified that the motor operation in a certain line can be simulated with this platform well. In addition, the starting speed of braking is high because of the operation strategy. The difference of the power scale readings is 90WH in this operation simulation.

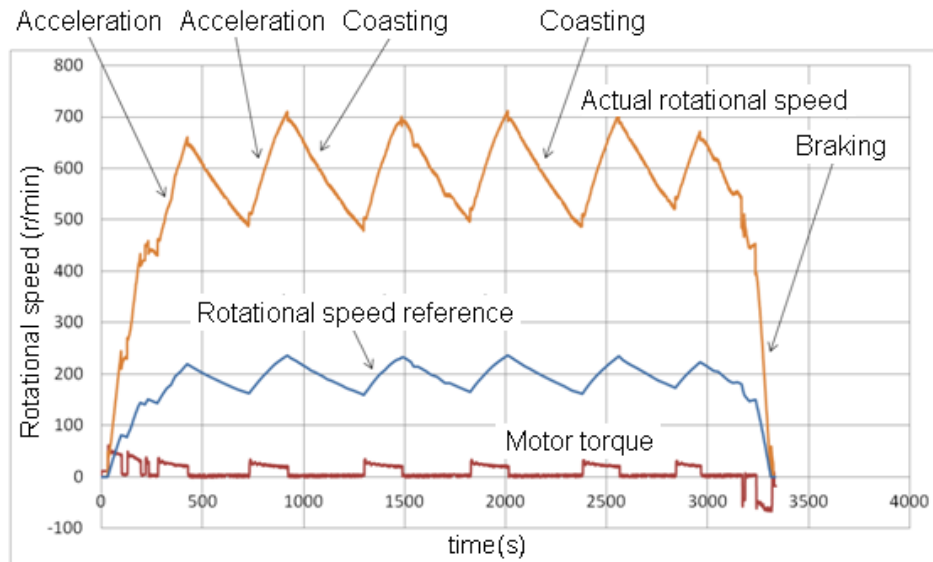

Fig.5 The speed and torque waveform in the average distribution strategy

Secondly, dynamic programming fixed time operation strategy is applied in the operation simulation [6]. Fig. 6 shows the result. In Fig. 6, the work of the motor is on the average. The difference of the power scale readings is 85WH in this operation strategy. It means that the energy consumption of a single motor is 85WH simulated by the continuous line load simulation platform.

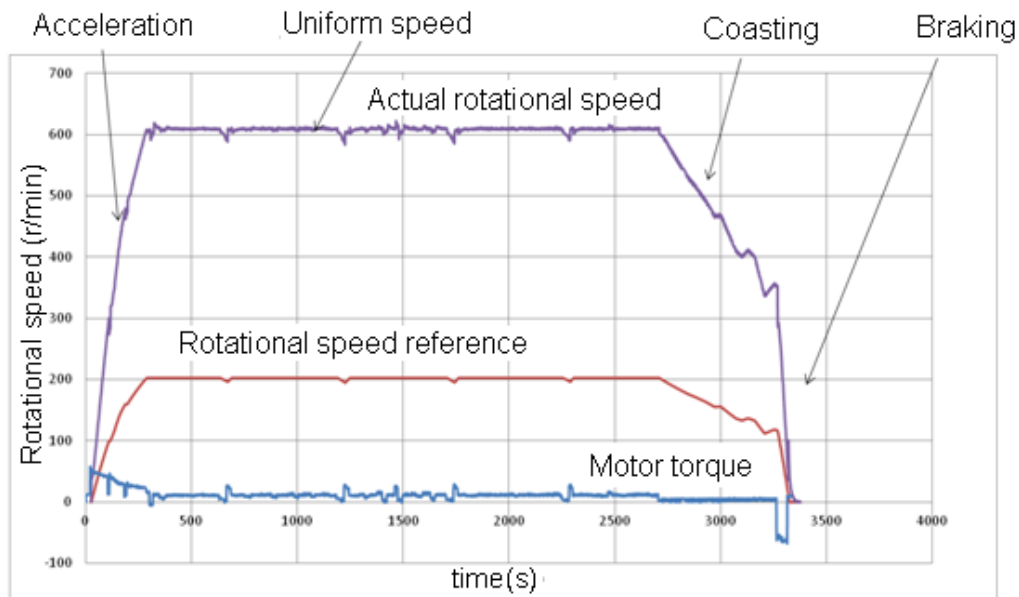

Fig. 6 The speed and torque waveform in the dynamic programming operation strategy

It is shown that the dynamic programming operation strategy is more power frugal than the distributing time equally operation strategy. This platform can support the study on energy-saving operation strategy of high-speed train in experiment.

Summary

The study platform which contains software and experiment has been built up elementary aiming at the original intention. Availability of the study platform is verified according to some experiment and simulation results. With sustained development of the platform, co-simulation and experiment based on it will be more multifunctional.

Acknowledgements

This work is supported by two grants from National Key Technology Support Program (2009BAG12A01-F15-1 and 2009BAG12A05) and a research fund from Beijing Jiaotong University (2012YJS107).

Corresponding Author

Xiaochun Fang. Email: me330221789@126.com. Mobile phone: (86)18610010196.

References

- [1] High speed lines in the world. *Online referencing* 3(4), <http://www.uic.org/spip.php?article573> (2011, accessed 15 July 2012).
- [2] Mid/Long-Term Development Planning of China Railway. Beijing, China, 2008. (In Chinese)
- [3] Xiaochun Fang, Zhongping Yang, Fei Lin, Ke Li, Huaiyu Xu, Jianying Liang. A CAD software for traction drive system of high-speed train led by top-level technology goals. In: *1st International Workshop on High-Speed and Intercity Railways*, Shenzhen and Hong Kong, China, 19-22 July 2011, pp.441-451.
- [4] Zeyu Yi, Zhongping Yang, Sijie Li, Fei Lin and Wenzheng Liu. Study on the control method of

high-speed train traction motor continuous load. In: *1st International Workshop on High-Speed and Intercity Railways*, Shenzhen and Hong Kong, China, 19-22 July 2011, pp.473-481.

- [5] Musallam M, Johnson CM. Real-time compact thermal models for health management of power electronics. *IEEE Transactions on Power Electronics* 2010; 25(6): 1416-1425.
- [6] Si J, Lei Yang, Chao Lu, et al. Approximate dynamic programming for continuous state and control problems. In: *17th Mediterranean Conference on Control and Automation*, Thessaloniki, Greece, 24-26 June 2009, vol.3, 1415-1420.